

Description

Single pole thermal-magnetic circuit breaker with tease-free, trip-free, snap action mechanism and two button operation (M-type TM CBE to EN 60934). Featuring a narrow profile housing, recessed terminals, standard EN rail mounting, and precision CBE performance. Approved to CBE standard EN 60934 (IEC 60934).

Typical applications

Process control systems, instrumentation, rail vehicles.

Ordering information

Type No.	
201	single pole, rail mounted version
201-WA	low-resistance version
	Option
2705	fitted with adapter X 200 409 01
	Current ratings
	0.05...16 A (type 201)
	0.05...10 A (type 201-WA)
201 - .. - - 10 A ordering example	

The exact part number required can be built up from the table of choices shown above. Ordering references for optional features should be omitted if not required.

Standard current ratings and typical internal resistance values

Current rating (A)	Internal resistance (Ω)		Current rating (A)	Internal resistance (Ω)	
	201	201-WA		201	201-WA
0.05	447	211	3	0.19	0.054
0.1	131	48	4	0.090	0.035
0.2	40	12.4	5	0.061	0.025
0.3	19.3	5.7	6	0.041	< 0.02
0.4	10.4	3.1	7	0.034	< 0.02
0.5	7.1	2.0	8	< 0.02	< 0.02
0.6	4.3	1.32	10	< 0.02	< 0.02
0.8	2.5	0.76	12	< 0.02	< 0.02
1	1.67	0.49	14	< 0.02	< 0.02
1.5	0.61	0.21	15	< 0.02	< 0.02
2	0.38	0.101	16	< 0.02	< 0.02
2.5	0.24	0.078			

Approvals

Authority	Voltage ratings	Current ratings
VDE (EN 60 934)	AC 240 V; DC 65 V	0.05...16 A
CSA, UL	AC 250 V; DC 80 V	0.05...16 A
UL (only type 201)	DC 65 V	0.05...25 A

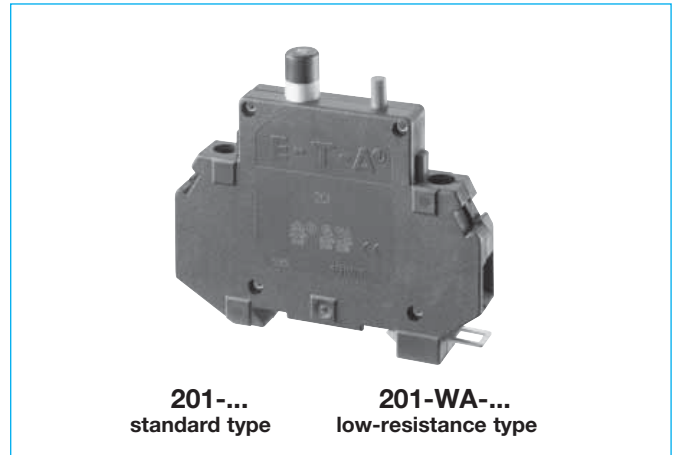

Technical data

For further details please see chapter: **Technical Information**

Voltage rating	AC 240 V (50/60 Hz); DC 65 V (UL: AC 250 V; DC 80 V)		
Current rating range	201: 0.05...16 A 201-WA: 0.05...10 A		
Typical life	5,000 operations at 1 x I _N , inductive 5,000 operations at 2 x I _N , resistive		
Ambient temperature	-30...+60 °C (-22...+140 °F)		
Insulation co-ordination (IEC 60664 and 60664 A)	rated impulse withstand voltage 2.5 kV reinforced insulation	pollution degree 2 in operating area	
Dielectric strength (IEC 60664 and 60664A) operating area	test voltage AC 3,000 V		
Insulation resistance	> 100 MΩ (DC 500 V)		
Interrupting capacity I _{cn}	201 0.05...0.8 A 1...2 A 2.5...16 A	201-WA 0.05...0.2 A 0.3...2 A 2.5...10 A	self-limiting 200 A 400 A
Interrupting capacity (UL 1077)	I _N 0.05...16 A 0.05...16 A	U _N AC 250 V DC 80 V	1,000 A 1,000 A
Degree of protection (IEC 60529/DIN 40050)	operating area IP40 terminal area IP20		
Vibration	5 g (57-500 Hz), ± 0.38 mm (10-57 Hz) to IEC 60068-2-6, test Fc 10 frequency cycles/axis		
Shock	25 g (11 ms) to IEC 60068-2-27, test Ea		
Corrosion	96 hours at 5 % salt mist, to IEC 60068-2-11, test Ka		
Humidity	240 hours at 95 % RH to IEC 60068-2-78, test Cab		
Mass	approx. 60 g		

Dimensions

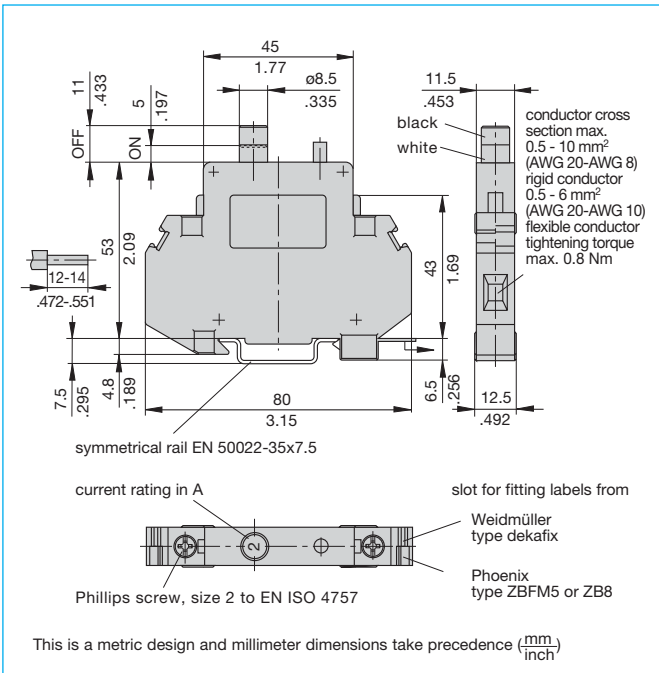

Installation drawing

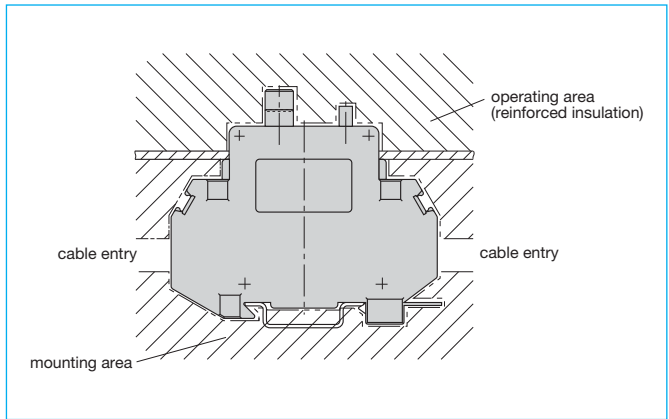

Internal connection diagram

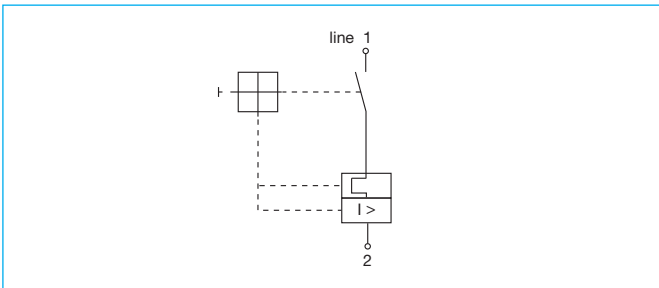

The time/current characteristic curve depends on the ambient temperature prevailing. In order to eliminate nuisance tripping, please multiply the circuit breaker current ratings by the derating factor shown below. See also section Technical information.

Ambient temperature °F	-22	-4	+14	+32	+73.4	+104	+122	+140
°C	-30	-20	-10	0	+23	+40	+50	+60
Derating factor	0.76	0.79	0.83	0.88	1	1.08	1.16	1.24

Typical time/current characteristics

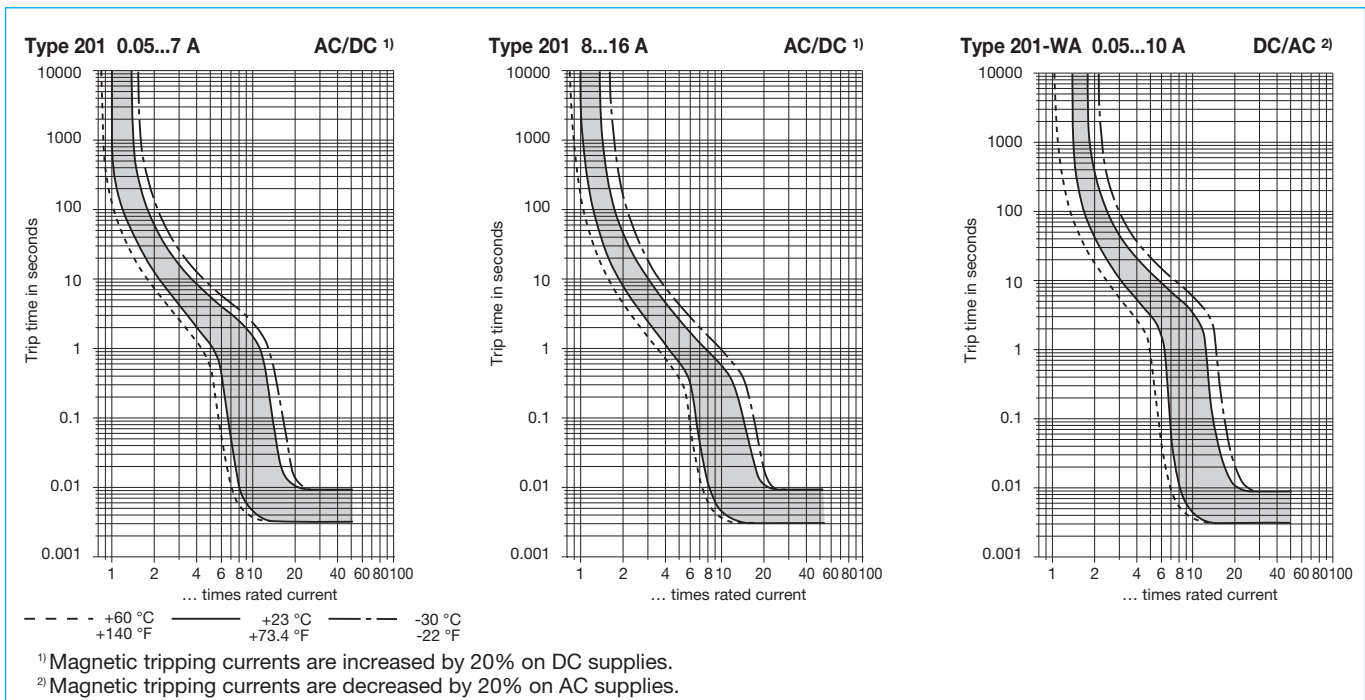

Accessories

Busbar 1-pole, 90° X 222 540 01

The one metre long busbars can be cut to suitable lengths. Plug-on caps can be fitted on the ends to provide brush contact protection.
I_{max} - busbar 100 A (40 °C)

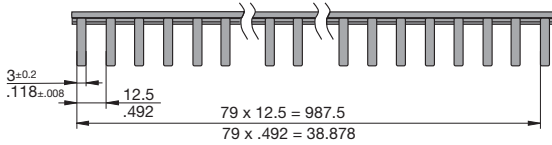

Plug-on cap, 1-pole Y 307 851 01

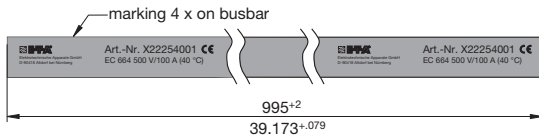
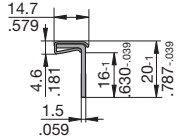

Supply terminal I_{max} 63 A Y 308 551 01

Max. tightening torque of terminal screw 2 Nm
Max. cable cross section: 25 mm² / single strand
16 mm² / multistrand with wire end ferrule

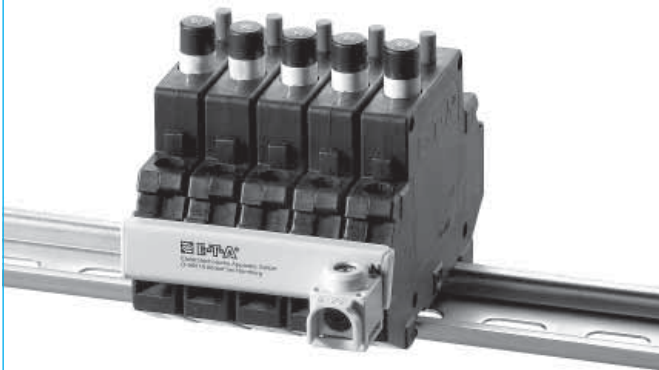
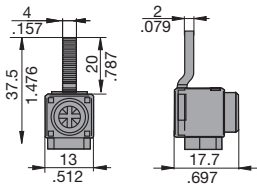

Adapter for EN rail 50035-G32 specified as a separate item X 200 409 01

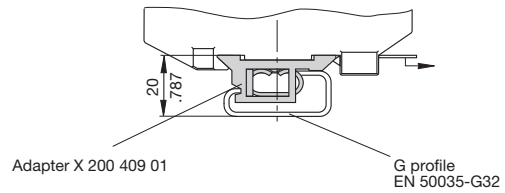

Connector bus links -K10

X 210 589 01/2.5 mm², (AWG 14) (black) up to 20 A max. load
X 210 589 02/1.5 mm², (AWG 16) (brown) up to 13 A max. load

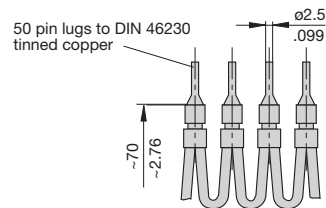

This is a metric design and millimeter dimensions take precedence ($\frac{\text{mm}}{\text{inch}}$)

All dimensions without tolerances are for reference only. In the interest of improved design, performance and cost effectiveness the right to make changes in these specifications without notice is reserved. Product markings may not be exactly as the ordering codes. Errors and omissions excepted.