

Description

Monostable power relay for single pole disconnection with a variety of versions available. Due to the possible combinations of the different configurations as well as due to different modes of mounting the power relay D1 is suitable for many applications.

Typical applications

Commercial vehicles, agricultural vehicles, watercraft, construction vehicles, motor homes and industrial trucks.



PR60

Technical data

Continuous current	100 A, 200 A, 300 A		
Coil data			
Rated voltage	DC 12 V	DC 24 V	DC 48 V
Operating voltage	9...16 V	18...32 V	36...54 V
Coil power	approx. 10 W / 7 W upon request	approx. 10 W	approx. 10 W
Ambient temperature	-40 °C...+85 °C		
Protection class			
interior	IP67 (0.2 bar: 1 min) to IEC 529		
terminals	IP00 to IEC 529		
Vibration	6 g (50-2000 Hz)		
Shock	40 g (11 msec)		
Resistance to	oil, fuel, hydraulic fluids		
Housing	galvanized steel, tin-plated or lacquered optional		
Mounting method	side mount, optionally large or small foot mount		
Options	special version with suppressor diode and/or blow magnet		
Terminal thread	100 A: M8 200 A: M8 or M10 300 A: M10		
Mounting position	any		
Switching element	contacts AgSnO		
Min. insulation resistance	100 MΩ		
High voltage resistance	1,050 V for 1 min		
Max. initial contact voltage drop	150 mV		
ON duty	100 %		
Overload (ampacity in closed condition)	100 A: 800 A for 1 s, 200 A for 20 s 200 A: 1 600 A for 1 s, 400 A for 20 s 300 A: 2 400 A for 1 s, 600 A for 20 s		
Typical life			
rated load Ω	75,000 cycles (at DC 28 V)		
mechanically	1,500,000 cycles		
Starting time incl. bounce duration	max. 40 ms		
Bounce duration	max. 5 ms		
Release time	max. 20 ms (without suppressor diode)		
Cable cross section at rated load	100 A: min. 50 mm ² 200 A: min. 70 mm ² 300 A: min. 95 mm ²		
Mass	approx. 810 g (side mount, small foot mount) approx. 935 g (large foot mount)		

Dimensions

PR60-...-3

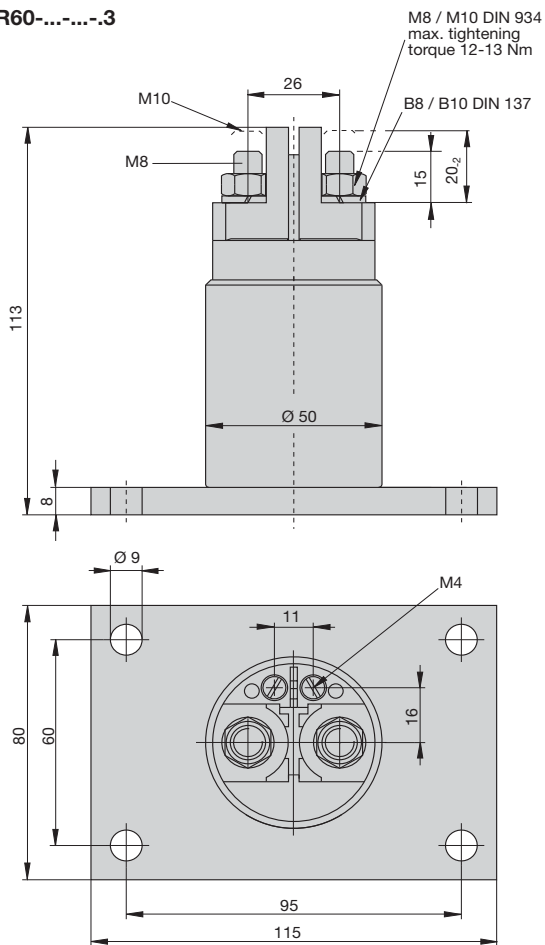

Current rating 100 A: terminal thread M8
 Current rating 200 A: terminal thread M8 or M10
 Current rating 300 A: terminal thread M10
 Nominal dimensions without direct tolerance indication: IT 14 DIN ISO 286

PR60-...-3-.. with blow magnet

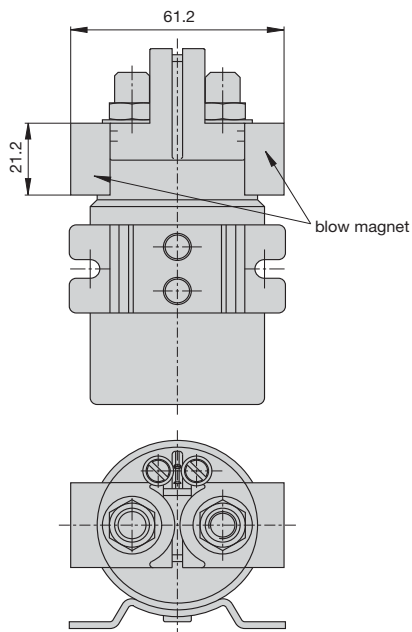

Accessories

Suppressor diode
 X 223 02 901

