

Description

Miniaturised single pole thermal-magnetic circuit breakers with trip-free mechanism and toggle actuation (S-type TM CBE to EN 60934). Two designs provide the option of either printed circuit board or threadneck panel mounting. A separate shunt tap terminal and auxiliary contacts are available. Fast acting, medium or long delay characteristics can be specified for both models.

Suitable for use in distribution rails – see section Power Distribution Systems.

Complies with CBE standard EN 60934 (IEC 60935).

Typical applications

Control equipment, communications systems, instrumentation.
Suitable for mounting on Euro cards.

Ordering information 2215-G1

Type No.

2215 single pole thermal-magnetic circuit breaker

Mounting

G1 threadneck panel mounting

Number of poles

1 1-pole protected

Mounting hardware

1 2 hex nuts 1/4"-40 UNS-2A, serrated washer, location pin (-G1 only)

Terminal design (main contacts)

P1 blade terminals 6.3-0.8, without shunt terminal

Characteristic curve

F1 fast acting: 1.01-1.4xI_N; magn. 2-4xI_N DC (DC only)

M1 standard delay: therm. 1.01-1.4xI_N; magn. 4.5-10.5xI_N DC; magn. 3.5-8xI_N AC

T1 delayed: therm. 1.01-1.4xI_N; DC magn. 8-17xI_N DC, 6-13xI_N AC

Auxiliary contacts

S0 without auxiliary contact

S11 with auxiliary contact (change over) blade terminals 6.3x0.8 (QC .250)

Current ratings

0.05...10 A

2215 - G1 1 1 - P1 F1 - S11 - 0.5 A ordering example

Ordering information 2215-L1

Type No.

2215 single pole thermal-magnetic circuit breaker

Mounting

L1 PCB mounting

Number of poles

1 1-pole protected

Mounting hardware

0 without accessories

Terminal design (main contacts)

L1 solder pins, without shunt terminal

Characteristic curve

F1 fast acting: 1.01-1.4xI_N; magn. 2-4xI_N DC (DC only)

M1 standard delay: therm. 1.01-1.4xI_N; magn. 4.5-10.5xI_N DC; magn. 3.5-8xI_N AC

Auxiliary contacts - terminal design

S0 without auxiliary contact

S12 with auxiliary contact (change over) solder pins

Current ratings

0.05...10 A

2215 - L1 1 0 - L1 F1 - S12 - 0.5 A ordering example



2215-L1..



2215-G1...

Technical data

Voltage rating	AC 250 V (50/60 Hz); DC 50 V (UL: AC 250 V; DC 75 V)		
Current rating range	0.05...10 A (higher current ratings to special order)		
Auxiliary circuit	1 A, AC 250 V / DC 28 V		
Typical life	10,000 operations at 1 x I _N		
Ambient temperature	-30...+60 °C (-22...+140 °F)		
Insulation co-ordination (IEC 60664 and 60664 A)	rated impulse withstand voltage 2.5 kV reinforced insulation in operating area	pollution degree 2	
Dielectric strength IEC 60664 and 60664A)	test voltage operating area main/aux. circuit	AC 3,000 V AC 1,500 V	
Insulation resistance	> 100 MΩ (DC 500 V)		
Interrupting capacity I _{cn}	300 A		
Interrupting capacity (UL 1077)	I _N	U _N	
	0.05 A	AC 250 V	200 A
	0.1...6 A	AC 250 V	1,000 A
	8...10 A	AC 250 V	2,000 A
	0.05...10 A	DC 50 V	1,000 A
Degree of protection (IEC 60529/DIN 40050)	operating area IP30 terminal area IP00		
Vibration	curve F1: 6 g (57-500 Hz), ± 0.46 mm (10-57 Hz) curves M1, T1: 8 g (57-500 Hz), ± 0.61 mm (10-57 Hz) to IEC 60068-2-6, test Fc 10 frequency cycles/axis		
Shock	curves F1, M1, T1: 30 g (11 ms), directions 1, 2, 3, 4, 5, curve F1: 10 g (11 ms), direction 6 curves M1, T1: 15 g (11 ms), direction 6 to IEC 60068-2-27, test Ea		
Corrosion	96 hours at 5 % salt mist to IEC 60068-2-11, test Ka		
Humidity	240 hours at 95 % RH to IEC 60068-2-78, test Cab		
Mass	approx. 25 g		

Approvals

Authority	Voltage ratings	Current ratings
UL	AC 250 V	0.05...10 A
CSA	AC 250 V; DC 48 V	0.05...10 A

Standard current ratings and typical internal resistance values

Current ratings (A)	Internal resistance (Ω)	Current ratings (A)	Internal resistance (Ω)
0.05	440	1.5	0.55
0.1	108	2	0.34
0.2	29.9	2.5	0.21
0.3	14.2	3	0.15
0.4	7.9	4	0.084
0.5	5.0	5	0.057
0.6	3.5	6	0.043
0.8	1.8	8	≤ 0.02
1	1.2	10	≤ 0.02

Dimensions 2215-L1..

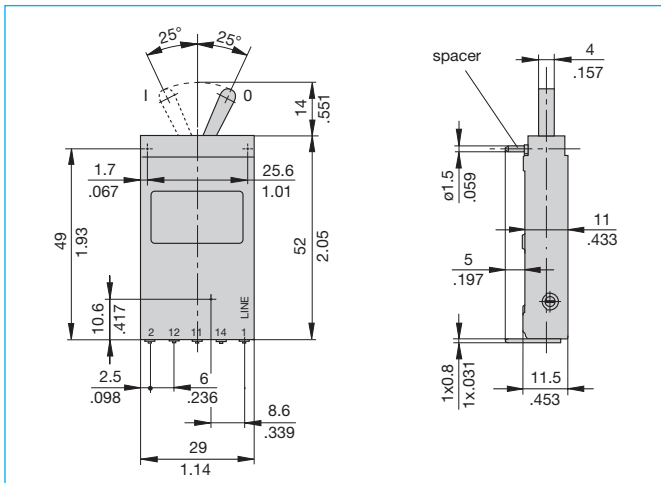

Dimensions 2215-G1..

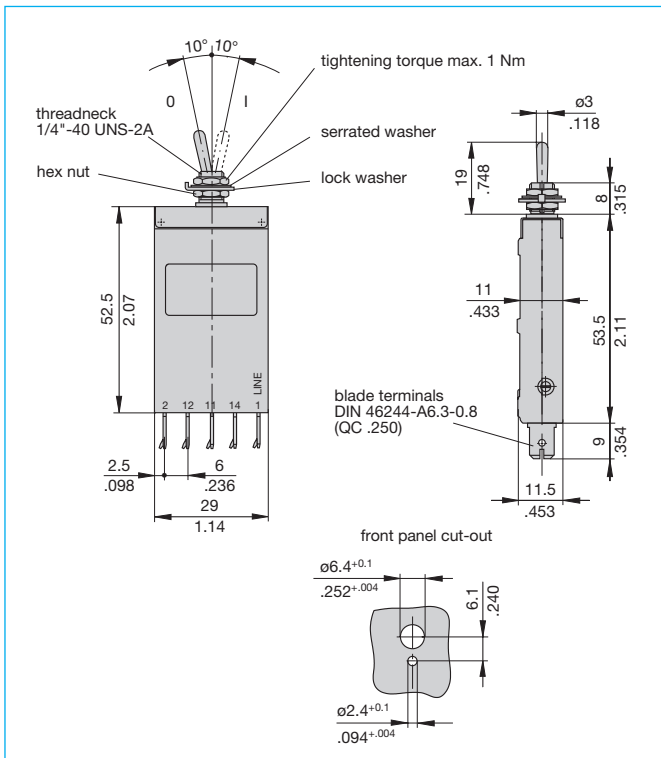

Installation drawing

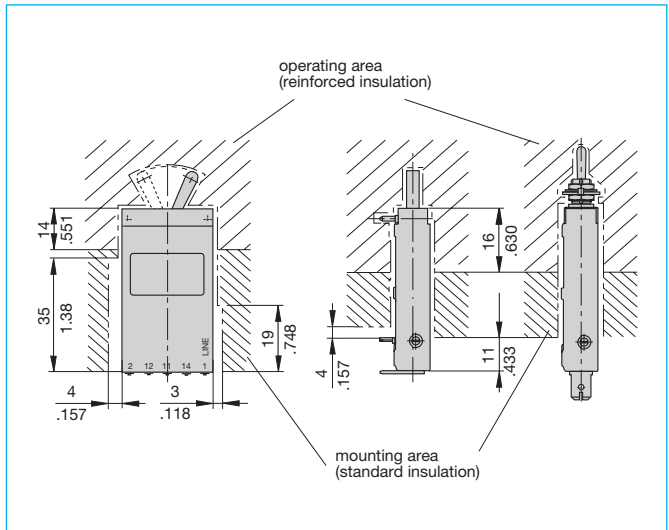

Internal connection diagram

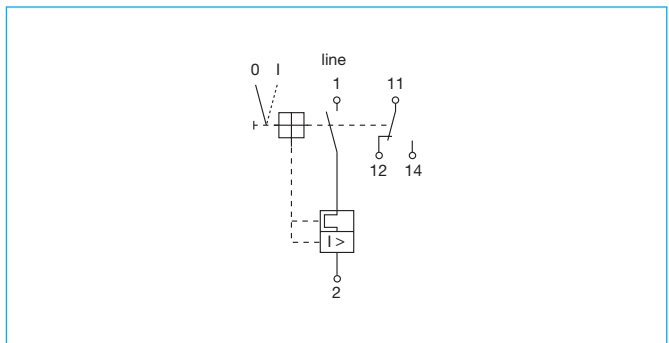

Shock directions

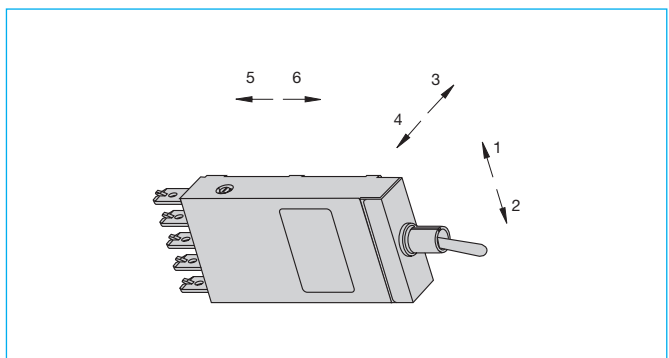

This is a metric design and millimeter dimensions take precedence ($\frac{\text{mm}}{\text{inch}}$)

Typical time/current characteristics

-F1 0.05...6 A

DC only

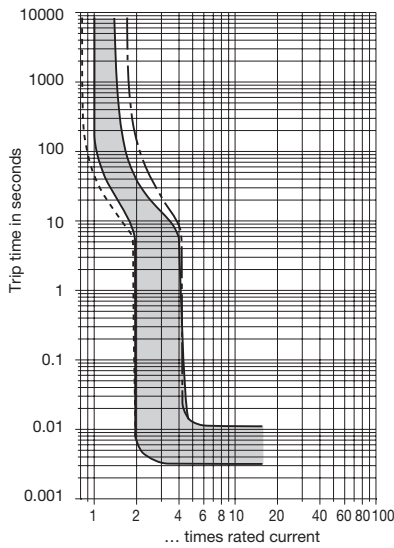

-F1 8...10 A

DC only

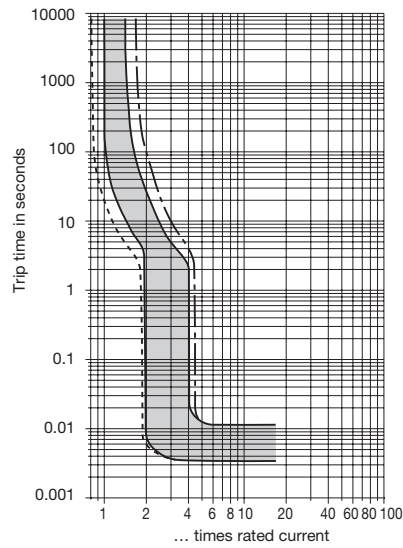

-M1 0.05...6 A

AC/DC ¹⁾

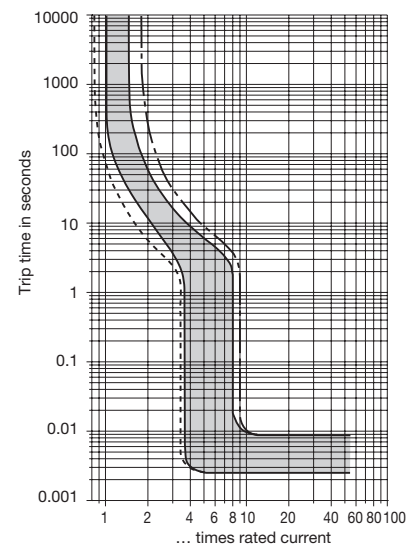

-M1 8...10 A

AC/DC ¹⁾

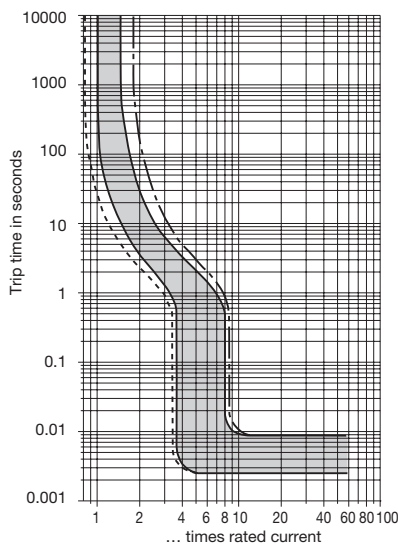

-T1 0.05...6 A

AC/DC ¹⁾

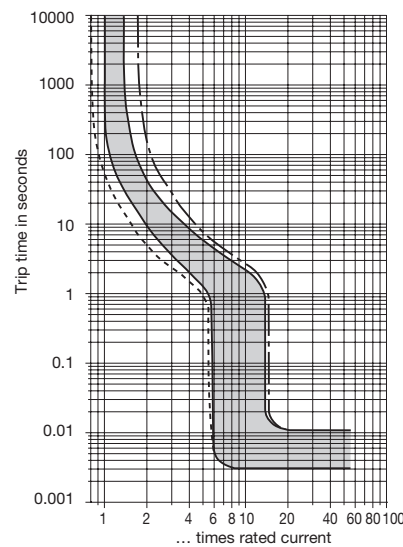

-T1 8...10 A

AC/DC ¹⁾

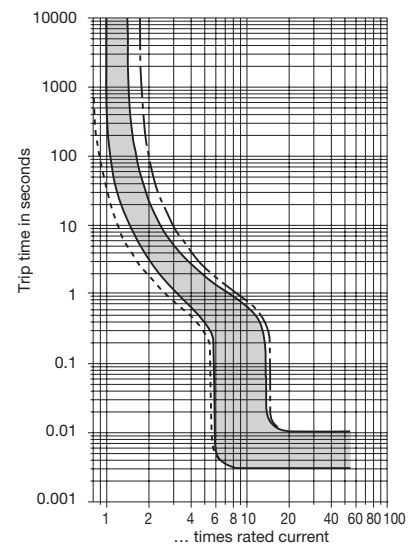

--- +60 °C / +140 °F ——— +23 °C / +73.4 °F - · - · -30 °C / -22 °F

¹⁾Magnetic tripping currents are increased by 30 % on DC supplies (curve M1 and T1).

0.05...10 A:

Ambient temp. °F	-22	-4	+14	+32	+73.4	+86	+104	+122	+140
temp. °C	-30	-20	-10	0	+23	+30	+40	+50	+60
Derating factor	0.76	0.79	0.83	0.88	1	1.04	1.11	1.19	1.29

The time/current characteristic curve depends on the ambient temperature prevailing. In order to eliminate nuisance tripping, please multiply the circuit breaker current ratings by the derating factor shown below. See also section Technical information.

All dimensions without tolerances are for reference only. In the interest of improved design, performance and cost effectiveness the right to make changes in these specifications without notice is reserved. Product markings may not be exactly as the ordering codes. Errors and omissions excepted.